

# North American Occupational Dose Trends

North American Technical Center, ISOE  
Cook Nuclear Plant  
American Electric Power

ISOE-ATC 2005 ALARA Workshop  
9-10 November 2005  
Hamaoka, Japan

# 2004 US BWR Dose Trends

- 35 US operating BWRs reported total collective dose of 54.510 person Sv.
- Average Dose per Reactor was **1.56 person Sv/ unit**
- 2004 Average Dose represents a **3% increase** from 2003.
- 2004 Average Dose was the second lowest recorded average dose per unit since 1969.
- The lowest US BWR Average Dose was in 1.38 person Sv per unit recorded in 2001.

# US BWR Sites with High Doses

	2003	2004
■ Dresden 2,3	3.5 Sv	3.8 Sv
■ LaSalle 2,3	3.6	4.6
■ Peach Bottom 1,2	2.6	3.6
■ Quad Cities 1,2	4.4	5.1

High annual site doses due to continued water chemistry challenges & large repair jobs.

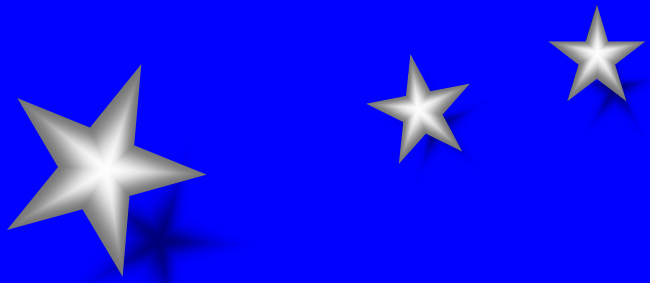

# *D.C. Cook Plant*

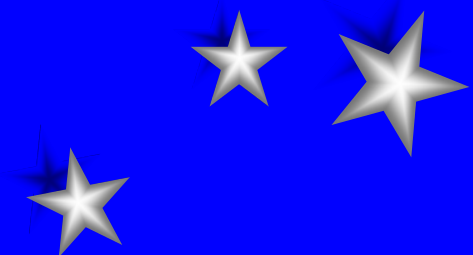

# 2004 US PWR Dose Trends

- Total collective dose for PWRs was 49.160 person Sv for 69 operating PWR units
- Average collective dose per reactor was **0.71 person Sv per unit**
- Represents a **22% decrease** in average dose from 2003 of 0.91 person Sv per unit.
- 2004 US PWR Average collective dose is the lowest average dose ever recorded in the US.
- Sixth time since 1969 below 1.00 person Sv/unit

# Outage Duration Achievements

- US nuclear plants generated 21% of nation's electricity in 2004
- Net capacity factors for all units have increased from 70% in 1991 to 90% in 2004
- Equivalent to the additional electricity generated from 13 new 1000 megawatt plants due to the shortening of refueling and maintenance outages.
- Average/mean outage duration for US LWRs have decreased from 105/76 days in 1990 to 36/34 days in 2004

# Reasons for Lower PWR Doses

- The record low 2004 average collective doses reflect the US nuclear industries' continued commitment to ALARA by implementing effective exposure reduction initiatives including:
  - Source term reduction programs.
  - Efficient refueling outages.
  - On-line & shutdown chemistry controls.
  - INPO 2005 PWR fleet average target of 0.65 person Sv/yr.



# FPL 1st Integration

Turkey Point 3/2000, St Lucie 4/2000



1st Use

March 2000

Turkey Point 3





# Activity

## CFD Code Analysis: FLUENT

1. Iron Oxyanions Form in RCS during Shutdown
2. Iron Gels Stick/Deposits in CRUD Traps
3. Co-58, Co-60, Nickel diffuses from bulk RCS to boundary layer of gels where it "Sticks" or co-precipitates into Iron Gels
4. Result increased dose rates, contamination levels a
5. Impossible to complete a mass balance: Released - Deposited - Removed

CVCS = 0



Co-58, Ni Diffusion  
Co-Precipitation

Vector Plot: Velocity [m/s]

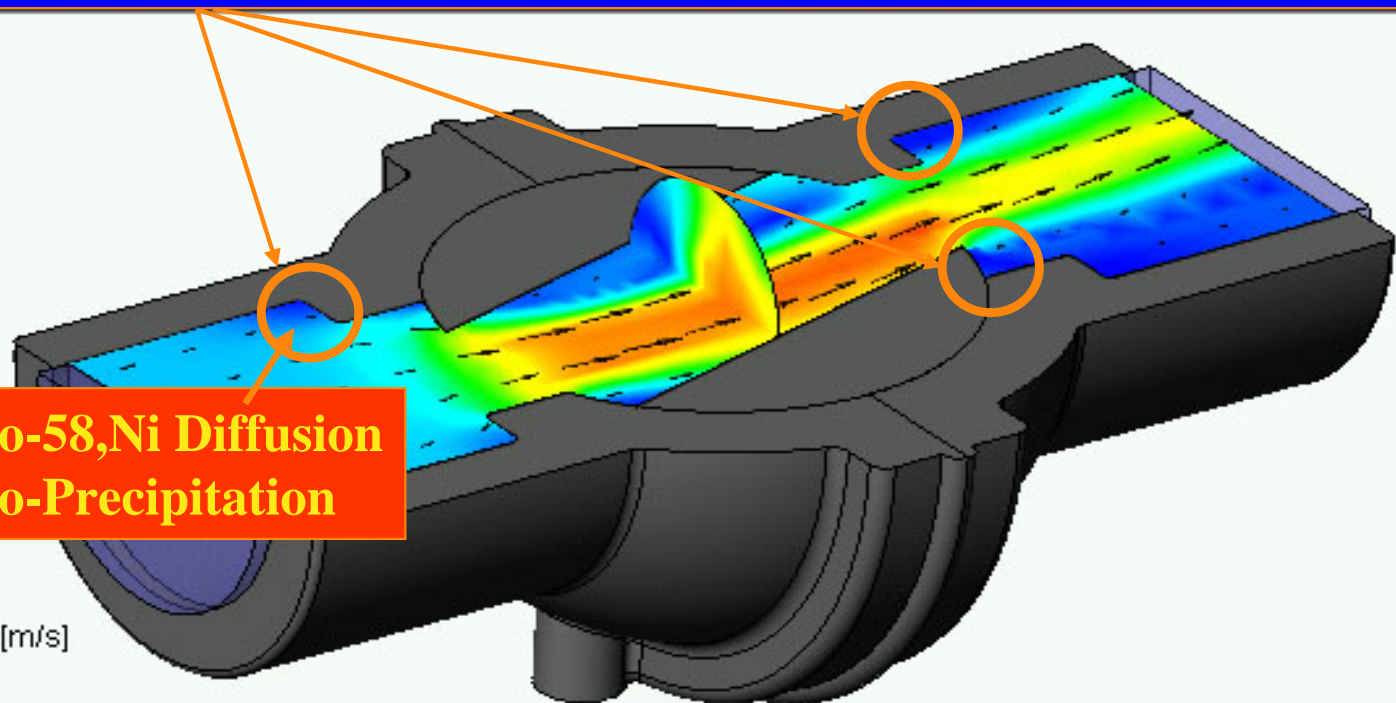

# Plant Life Extensions Continue

- US NRC Plant-life extensions permit 20 additional years of full power operation.
- The US NRC has granted additional plant-life extensions in 2004 and 2005:
  - Robinson-2 April, 2004
  - Summer April 2004
  - Ginna May 2004
  - Cook September 2005
- Assists some US RPMs in securing senior management approval for ALARA investments in permanent work platforms and permanent shielding, etc. (due to longer cost/benefit analysis justification).

# PWR Reactor Vessel Head Replacements

- Since the Davis Besse incident in February 2002, all US PWRs have inspected their reactor vessel heads to determine if nozzle cracks have occurred.
- US replacements of reactor heads have been completed at Davis Besse, Oconee, Surry, North Anna, TMI-1, and Crystal River in 2003; Kewaunee in 2004; Point Beach 2 & Palo Verde, 1 in 2005.
- NATC ISOE developed 20 standardized radiation work permit (RWP) categories in 2003 based on EDF experience.
- Standardized RWPs allow PWRs to track and compare dose, manhours and crew size for each head replacement project: excellent ALARA planning tool.

# Bottom Vessel Inspections at PWRs

- US NRC issued a bulletin on August 21, 2003, requesting bottom vessel inspections
- Based on South Texas Project, Unit 1, boric acid residue discovered on bottom mounted instrumentation penetrations in April, 2003
- South Texas Project cracks have been repaired.
- Other US Westinghouse PWRs are performing inspections.
- Combustion Engineering PWRs are inspecting top mounted in-core instruments (thimble tubes).

# Plant Staffing Levels

- US plant staffing level now average 798 employees for a single-unit site and 1116 employees for a dual-unit site.
- 2004 staffing is down 20% from the 1997 overall staffing levels
- Dual-unit PWRs have 15% higher staffing levels than a dual-unit BWR.
- Number of security guards at nuclear plants have increased significantly.
- San Onofre guard force increased from 100 to 400 over past 3-4 years.

# Adverse Trends Noted in RP

- Unplanned, Near-miss Overexposure Events.
- Radworker practices continue to need improvements at US sites.
- Practical radworker performance labs are used to challenge the worker's RP skills.

# ISOE Database Use in USA

- NATC organized pilot projects in the US in 2004 to encourage ISOE software use and secure end-user feedback.
- Good feedback on ISOE major component benchmarking datasets including:
  - Reactor head replacement
  - Pressurizer replacement
  - BWR power uprates
- Need ISOE databases to be on Internet.



# ISOE ALARA Symposia

- Excellent industry events, good practices and lessons learned information exchange for US RPMs
- Coordinated with US Region RP Manager's meeting was an important accomplishment for NATC in 2004 & 2005 and planned in 2006
- Symposia are strongly supported for professional training value to RPMs and their staffs. The 15-19, January 2006 North American ISOE ALARA Symposium is a key meeting for US RPMs to establish their next 5 year ALARA strategic plans to meet the 2010 INPO PWR & BWR goal targets.

# International Site Benchmarking

- JNES organized with NATC a US BWR ALARA benchmarking site visits to Fermi-2, Limerick 1,2, Susquehanna 1,2 and Dresden 2,3.
- Fermi-2 benchmarking site visit was completed in 6-11, February 2005.
- RP management discussion on following topics:
  - Hydrogen water chemistry during downpower
  - In-service inspection protocols
  - Use of revised postulated accident iodine source term.
  - Good information exchange “take aways” for guests and Fermi RP management.

# Participants in Fermi 2 ISOE Visit

- Eight radiation protection personnel from the following utilities participated in the Fermi 2 4-day site visit:
  - Tokyo Electric Power Company
  - Japan Atomic Power Company
  - Chubu Electric Power Company
  - TOHSHIBA Corporation
  - ATOX Co., Ltd.
  - Nuclear Safety Research Association
  - Japan Nuclear Energy Safety Organization (JNES)

# 2006 Japanese BWR Benchmarking US Site Visits

- The next US BWR ALARA site visits will occur start on 21, January 2006.
- Limerick 1,2; Susquehanna 1,2; Dresden 2,3 will be visited.
- Discussions with US NRC Health Physics Inspectors in Washington DC, King of Prussia, Pa & Lisle, Illinois are also planned.

# 2006 North American ISOE Symposium

- 15-19, January 2006 North American ISOE ALARA Symposium to be held at the Hilton Disney Resort, Orlando, Florida, US.
- Joint Meeting with EPRI's Radiation Protection Technical Conference.
- First Utility President & **new President of WANO** to be plenary speaker: Mr. Duncan Hawthorne, Bruce Power. He will speak about \$3.4 billion Bruce site refurbishment approved by Ontario provincial government in October, 2005.

# 2006 Symposium Topics

- Recognition of 2005 Nobel Peace Prize Award to IAEA organization & Dr. ElBaradei.
- Reiji Sundell, Plant Manager-TVO, Finland to discuss 7 day refueling outage in 2005
- Bruce Power's \$3 billion site refurbishment

# ISOE World Class ALARA Performance Award Competition

- Six North American sites competing for the award in 2005: Beaver Valley 1,2; Harris; Vogtle 1,2; & others.
- Past 5 awardee RPMs judge merits of each application and vote on winner.
- Selection criteria documented in NATC procedure.
- Site Vice President, Plant Manager, RPM make presentatons in plenary session



# EDF Site Visits in 2005

- RPMs from 3 EDF sites & Vice President- RP benchmarked the Cook 1,2 PWR site during a refueling outage in March 2005.
- Focus of site information exchange was on contamination control, access to upper containment in street clothes & remote monitoring
- Met with Senior Vice President
- Cook achieved an upgrade of 2 INPO rating levels in July, 2005 due to new site leadership.

# Future US Country ISOE Initiatives

- Completed US outage dose and duration databases each 6 months to reflect spring and fall outage results (helps sites know status for 2010 INPO industry dose goals)
- 15 ISOE 1 files for spring 2005 US NPP Refueling Outages submitted to ETC
- Expand pilot ISOE software projects
- Support PWR Head Replacement Projects
- Support PWR Steam Generator Replacement Projects
- Initiate new standardized RWP categories for Pressurizer Replacements (St. Lucie 1- 17, Oct.)

# Utility Mergers and Plant Sales

- Exelon plans to merge with PSEG ( Salem 1 & 2 & Hope Creek) which brings the total Exelon nuclear fleet to 20 nuclear units.
- Acquisition of Kewaunee by Dominion Energy for \$220 million for the reactor and fuel under contract. Also, Dominion Energy will gain access to decommissioning funds in escrow (\$193 million).
- Acquisition of 70% of Duane Arnold Energy Center by FPL Energy for \$387 million. FPL Energy will gain access to decommissioning funds in escrow (\$188 million).

# South Texas Project Ownership

- South Texas Project 1,2 ownership is still in transition. Texas Central Co., a unit of American Electric Power, decided to sell its 25.2% share in 2004.
- Cameco offered to purchase AEP's share.
- Other STP owners exercised first right of refusal.
- Texas Central, LP, largest owners, is in process of purchasing the AEP share.

# US BWR Challenges in 2003

- For first time in 20 years, significant fuel failures have been experienced at some US BWRs
- Noble Metal Addition protocols have been revised to reflect adverse experience at Quad Cities and Nine Mile Point

# 2005 NATC Mission

- Bring ISOE software and program to North American nuclear power plants
- Demonstrate benefits of ISOE membership to Radiation Protection Managers & utility senior management.
- Develop rapid means to distribute spring & fall refueling outage dose trends at pilot plants (Palo Verde Unit 1).
- Add 2005 Spring Outage Dose Results to ISOE 1 files (Nov. 05)
- Establish the Canadian ISOE CANDU ALARA Committee with annual meetings in June.
- Organize Japanese US BWR ALARA benchmarking project.

*D.C. Cook Plant*  
*ALARA Overview*

---

